

INTRODUCTION

The ultrasonic level Indicator is a low-cost, non-contact and easy-to-install measurement device. It is able to meet the every-day needs of commercial production, as well serving a more specialized role in the technologically-advanced aero-space industry, thus placing it firmly in the category of high-level measurement technology. Unlike other level indicators with limited uses, the easy-to-install ultrasonic level indicator is a highly-accurate device with enough specialized uses to ensure that the needs of the customer are met.

THEORY

The principle of operation of the ultrasonic sensor system is to use the ultrasonic pulses which are transmitted by the transducer to the surface to be monitored and are reflected back to the transducer, the time period between transmission and reception of the sound pulses is directly proportional to the distance between the transducer and surface, A micro-controller computes this time period for all echoes received and analyses them to determine which is the correct reflection from the material surface, it uses this data as the basis for giving control outputs and displays in usable engineering units. The distance D is determined from the velocity of sound v and the time period t by the formula:

$$D = v \cdot t / 2$$

Example:

With the velocity of sound $v = 334.1$ M/s, a time period of 60m/s corresponds to a transmission path of 20.046M and thus to a distance of 10.023M.

FEATURES

1. Non-contact.
2. Not effected by material property, such as pressure environments, viscosity and specific gravity.
3. Integrated keypad with security code.
4. Easy installation and low operating costs.
5. Can be used in a versatile of application .
6. Maintenance-free.
7. Easy to set program no need to train personal.
8. The distance between the transducer and control equipment can be up to 300M.
9. Fully isolated analog output.
10. Better accuracy and stability in difficult conditions.
11. Internal temperature compensation improves accuracy.

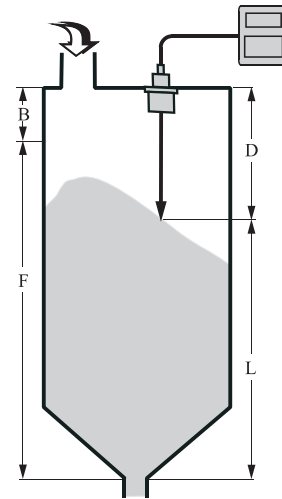

B = Blanking distance

D = Distance from transducer to material surface

L = Height in silo

MAIN FUNCTION

1. Level measurement (height above datum).
2. Distance measurement (distance from a datum).
3. Volume measurement.
4. Differential level measurement
5. Open channel flow measurement.
6. Pump control.

APPLICATION FIELD

1. Sewage/waste water/tapwater treatment equipment. Such as silos, open channels, dams and wells.
2. Liquids such as edible-oils, sauces, diesel oils and beverages.
3. Chemical material such as solvent, paints, carbonic acid, water, crude oil, epoxy resin, lime slurry and wax.
4. Granular materials such as flour, wheat and corn.
5. Chemical fibers, petrochemical materials such as plastic powders, plastic granules and plastic chips.

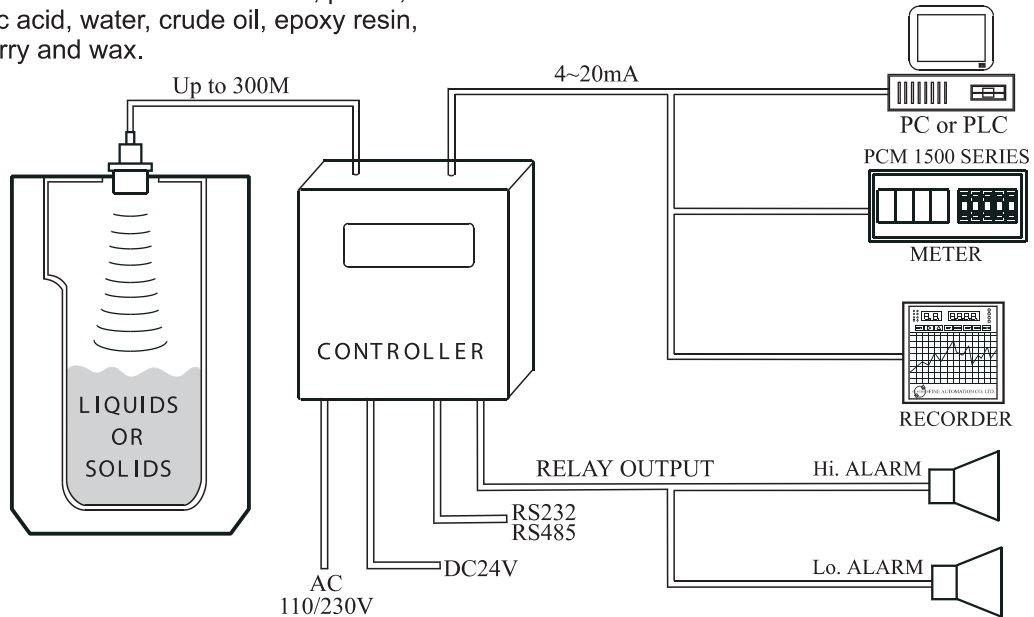

Liquid / Powder measurement

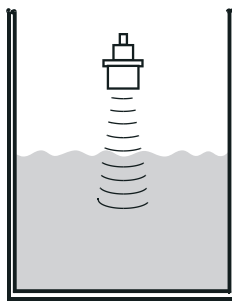

Silo with rotational aiming kit

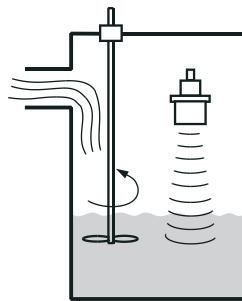

Flow measurement

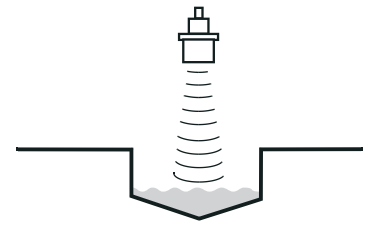

Foam thickness measurement

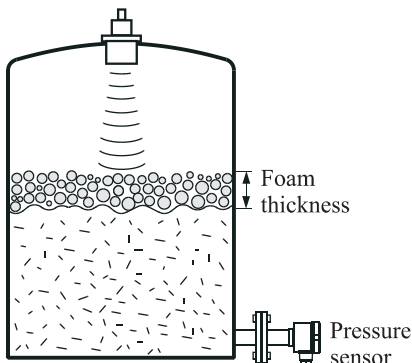

Measuring in agitator tank

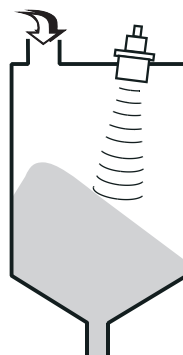

Material Mixing

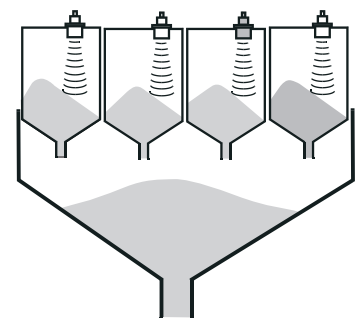

SPECIFICATIONS

Compact Type

**Model: EA-10P(CE)
EA-10F(CE)**

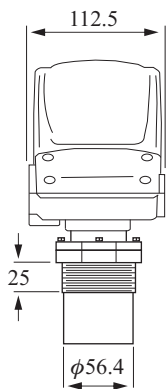
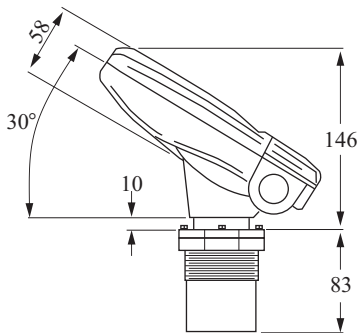

Measuring Range:	Refer to Table (1)
Power Supply:	12~28VDC (0.1A surge)
Operating Temp. (In tank):	-40°C ~ +70°C (-40°F ~ 158°F)
Mounting Screw:	2" NPT(std.) / 2" BSP
Measurement Accuracy:	0.25% of measuring range
Resolution:	3 mm (0.11")I
Housing Type:	Integrated (MonoBlock)
Housing Material:	ABS + UV
Enclosure:	IP65
Beam Angle:	5 @ 3db point
Sensor Material:	Aluminum coated ECTEF
Sensor Housing:	EA-10P: PP, EA-10F: (PVDF)
Display:	LCD (4-digits 7 segments)
Loop current:	2-wire 4~20mA, 750 Ohm @28VDC
Weight:	1.5 Kg (3.3Lb)
Certificates:	CE (EA-10P/F) ATEX (Option)

Table (1)

EA-10	Measuring Ranges	Dead Zone
For liquid (Standard)	15M (49ft.)	0.6M (2ft.)
For liquid (Short Range)	5M (16.5ft.)	0.25M (0.8ft.)
For solid (Standard)	8.5M (28ft.)	0.6M (2ft.)
For solid (Short Range)	5M (16.5ft.)	0.25M (0.8ft.)
For Open Channels	5M (16.5ft.)	0.2M (0.6ft.)

SPECIFICATIONS

Separate type

Model: EA-20



EAB-20 SENSOR
Cable: 15M (std.)

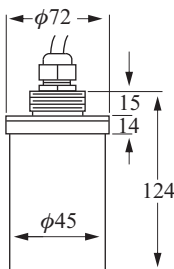
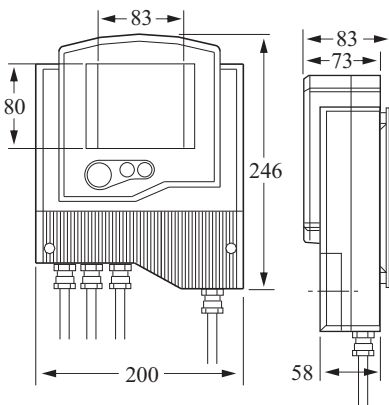

Measuring Range:	Refer to Table (2)
Power Supply:	100~240 VAC, 50~60Hz (std.) (via external power supply)
Operating Temp. (In tank):	-40°C ~ +100°C (-40°F ~ 176°F)
Mounting Screw:	1"NPT(std.) / 1"BSP
Measurement Accuracy:	0.1~0.25% of measuring range
Resolution:	1 mm (0.04")
Housing Type:	Separate
Housing Material:	ABS + UV
Enclosure:	IP65
Beam Angle:	5 @ 3db point
Sensor Material:	Glass reinforced Epoxy
Sensor Housing:	PP (std.) / PVDF
Display:	LCD
Communication (Options):	RS232, RS485 External Modem via RS232 (std.)
Loop Current:	4 wire 4~20mA, 750 Ohm @24VDC
PC Interface/ Remote Prog.:	Options: RS232, RS485
Trigger Points:	10 points (level)
Relays:	5 Independent SPDT
Weight:	2.5 Kg (5.5Lb)
Enclosure Dimensions:	272mm x200mm x 85mm
Certificates:	CE, FCC, 3A

Table (2)

EA-20	Measuring Ranges	Dead Zone	Accuracy
For liquid	12M (39ft.)	0.4M (1.3ft.)	0.2% of Measuring Range
For solid	8.5M (28ft.)	0.4M (1.3ft.)	0.25% of Measuring Range
Open Channels	12M (39ft.)	0.4M (1.3ft.)	0.2% of Measuring Range
Diameter	3M (8.2ft.)	0.5M (1.6ft.)	0.1% of Measuring Range

SPECIFICATIONS

Separate type

Model: EA-30



EAB-30 SENSOR
Cable: 25M (std.)

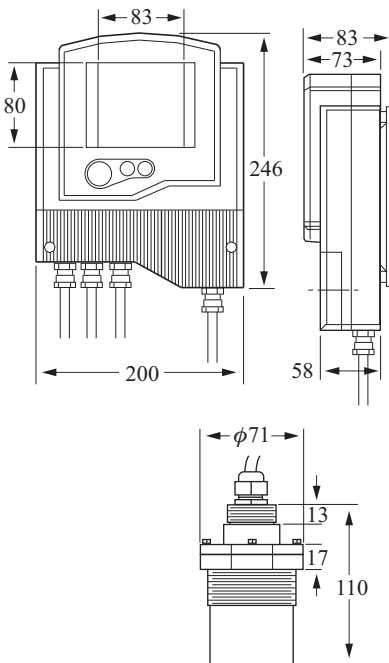

Measuring Range:	Standard: 25M for Liquids 20M for Solids Option: 40M for Liquids (Max) 30M for Solids (Max)
Power Supply:	100~240 VAC, 50~60Hz (std.) (via external power supply)
Operating Temp. (In tank):	-40°C ~ +80°C (-40°F ~ 176°F)
Mounting Screw:	1"NPT / 2"NPT / 1"BSP / 2"BSP
Measurement Accuracy:	0.25% of measuring range
Resolution:	1 mm (0.04")
Housing Type:	Separate
Housing Material:	ABS + UV
Enclosure:	IP65
Beam Angle:	5 @ 3db point
Sensor Frequency:	25KHz
Sensor Housing:	PP (std.) / PVDF
Display:	LCD
Communication (Options):	RS232, RS485 External Modem via RS232 (std.)
Loop Current:	4 wire 4~20mA, 750 Ohm @24VDC
PC Interface/ Remote Prog.:	Options: RS232, RS485
Trigger Points:	10 points (level)
Relays:	5 Independent SPDT
Weight:	2.5 Kg (5.5Lb)
Enclosure Dimensions:	272mm x200mm x 85mm
Certificates:	CE, FCC, 3A

INSTALLATION

Keep transducer perpendicular to liquid.

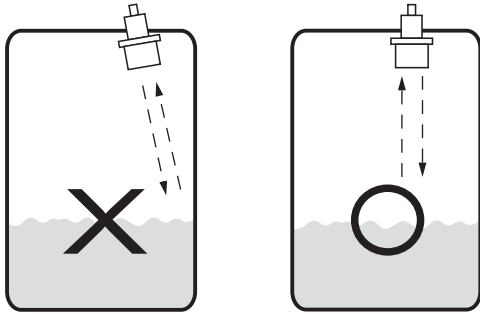

The transducer should not be mounted too close to the tank wall, the build-up on the tank wall cause false echoes.

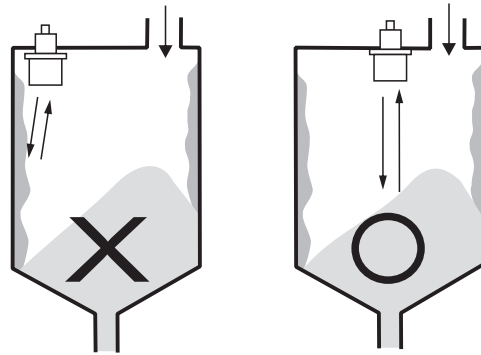

The transducer should not be mounted too close to the tank wall, the bracket can cause strong false echoes.

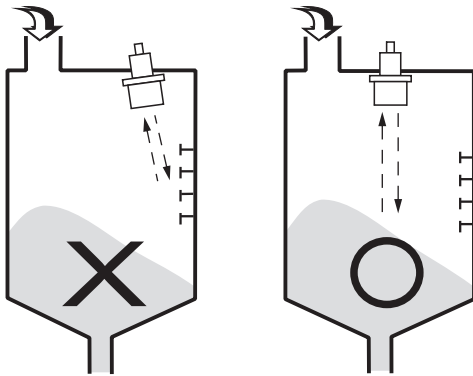

As is illustrated by the figure on the right, the transducer should be mounted on the top of guide tube to prevent the false echoes from turbulence and foam. The guide tube should come with a vent hole at top of the tube to allow the liquid vapor out of the tube.

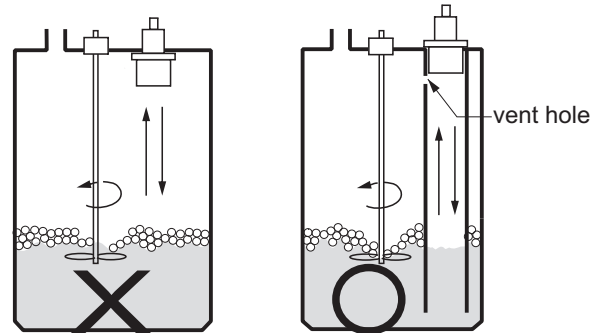

Mount the transducer away from the inlet to avoid false echoes.

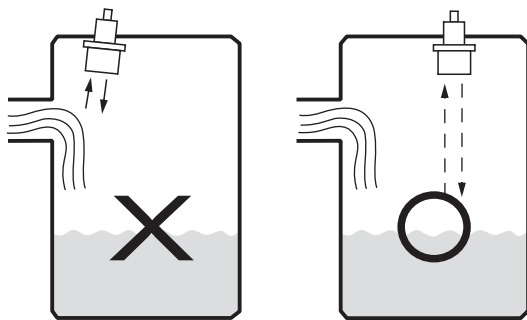

When you mount the transducer on the solid tank, the transducer must point to the tank outlet.

